



NHE 304/305

Mobile lifting and tipping equipment with electrohydraulic drive and a tipping angle of up to 90° for various areas of use and containers up to 1,500 kg

- ▶ Suitable for carrying standard and pallets
- ▶ Maximum tilt angle: 90°.
- ▶ Load capacity of up to 1,500 kg, depending upon model
- ▶ Maintenance electrohydraulic drive
- ▶ Stepless setting of working height tilt angle.
- ▶ As a standard design quipped with fork rakes standard.
- ▶ Two steering and two fixed casters. Steering wheels with brakes
- ▶ Low-maintenance and trouble-free operation due to high-quality robust components



NHE305

i AREAS OF APPLICATION

- Lifting and tilting heavy load carriers

TECHNICAL DATA

Equipment type	Load capacity (in kg)	Load handling (in mm)		Overlay (ZB in mm)	Extraction height (in mm)	Loading height (in mm)	Useful lift (in mm)	Tilt	Mobile possible
		BL	LL						
NHE 304	500	540	800	2 x 160 rakes	780	85	300	90°	✓
NHE 305	1.500	560	800	2 x 180 rakes	950	85	300	90°	✓

Power: 400 V/50 Hz, 16 A, 5-pole. Paint: RAL 7035/7016



Contact and advice:

+49 7161 98442-0
verkauf@ventzki.de

Or use our questionnaire at

www.ventzki.de/anfrage

NHE 305

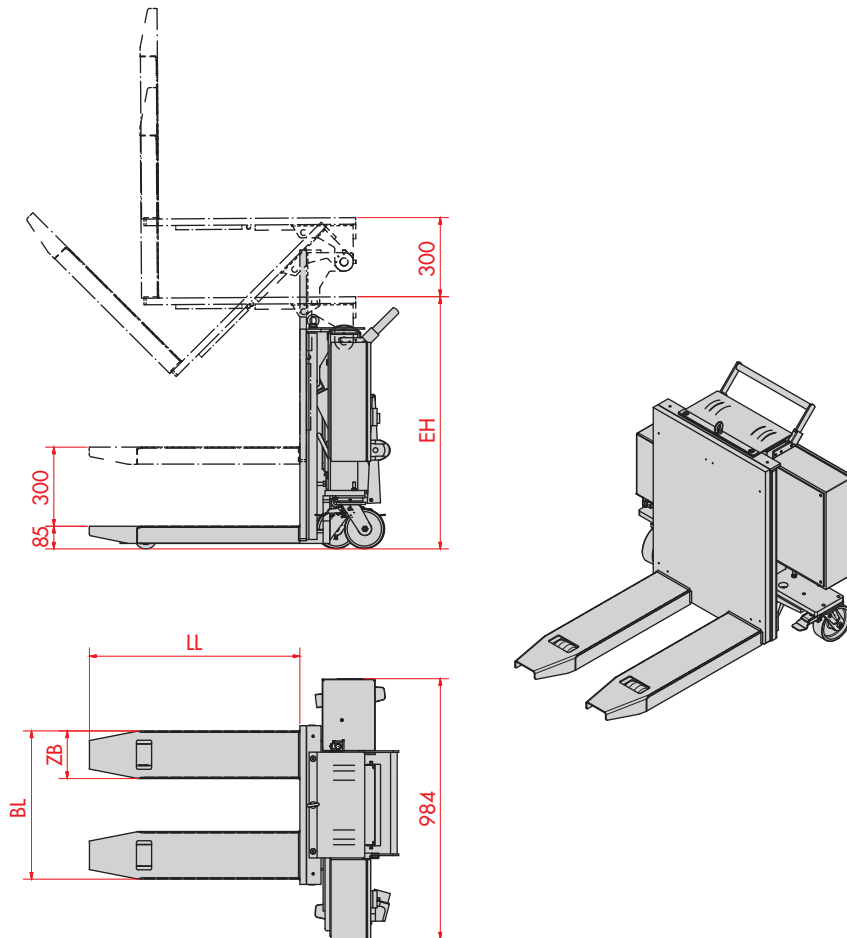

PRODUCT HIGHLIGHTS

- Mobile with steering and fixed rollers, casters with brakes
- Stepless setting of the lifting and tilting position
- Compact design